

# Enhancing Indoor IoT Communication with Visible Light and Ultrasound

Michael Haus<sup>†</sup>, Aaron Yi Ding<sup>‡</sup>, Qing Wang<sup>††</sup>, Juhani Toivonen<sup>\*</sup>, Leonardo Tonetto<sup>†</sup>, Sasu Tarkoma<sup>\*</sup>, Jörg Ott<sup>†</sup>

<sup>†</sup>Department of Computer Science, Technical University of Munich, Germany

<sup>‡</sup>Department of Engineering Systems and Services, Delft University of Technology, Netherlands

<sup>††</sup>Department of Electrical Engineering, KU Leuven, Belgium

<sup>\*</sup>Department of Computer Science, University of Helsinki, Finland

**Abstract**—The number of deployed Internet of Things (IoT) devices is steadily increasing to directly manage and interact with community assets of smart cities, such as transportation systems and power plants. This leads to a degraded network performance due to the growing amount of network traffic and connections generated by various IoT devices. To tackle these issues, one promising direction is to leverage the physical proximity of communicating devices and inter-device communication to achieve low latency, bandwidth efficiency, and resilient services. In this work, we aim at enhancing the performance of indoor IoT communication (e.g., smart homes, SOHO) by taking advantage of emerging technologies such as visible light and ultrasound. This approach increases the network capacity, robustness of network connections across IoT devices, and provides efficient means to enable distance-bounding services. We have developed communication modules using off-the-shelf components for visible light and ultrasound, and evaluate their network performance and energy consumption. In addition, we showcase the efficacy of our communication modules by applying them in a practical indoor IoT scenario to realize secure IoT group communication.

**Index Terms**—IoT, Visible light, Ultrasound, Multi-access, Edge Computing, Proximity-aware device grouping

## I. INTRODUCTION

The demands for network capability are steadily increasing due to the dense deployment of connected devices. For instance, almost half a billion mobile devices and connections were added globally in 2016 and 60% of the total mobile data traffic was offloaded onto the fixed network through Wi-Fi or femtocell [1]. In addition, the global mobile data traffic is estimated to increase by sevenfold between 2016 and 2021. Emerging applications, such as VR/AR, are demanding low latency and high computing capability for real-time interactions. In this respect, one important development is edge computing, which leverages the physical proximity of communicating devices to establish short communication paths. The edge approach fulfills the following network properties: high throughput, low latency, and reliability, all leading to an improved service completion time [2]. To realize resilient services, approaches like Wi-Fi HaLow, LoRa, SigFox, and NB-IOT address special requirements of IoT communications

This work was supported by the TUM Living Lab Connected Mobility Project, the Bavarian Ministry of Economic Affairs and Media, Energy and Technology (StMWi) through the Center Digitisation, Bavaria, and in part by the Intel Collaborative Research Institute for Secure Computing.

such as massive connectivity, frequent and small amount of transmitted data. In our context, IoT communication includes typical lightweight sensors, programmable boards, and user’s mobile devices like smartphones, tablets. One major problem is how to scale the inter-communication over the limited wireless spectrum. In densely deployed IoT networks where Wi-Fi and Bluetooth often interfere with each other, we can utilize emerging communication mechanisms such as Visible Light Communication (VLC) and ultrasound to bypass wireless interference. Combined with a smart IoT device management platform [3], we can orchestrate different IoT and edge devices to fully leverage wireless technologies and hence reduce wireless interference. Thereby, we are able to enhance network performance and save energy by avoiding redundant transmissions caused by wireless interference.

A unique property of VLC and ultrasound is that the communication range is naturally restricted by territorial obstacles, thus providing the basis for distance-bounding services. A distance-bounding service ensures an upper distance limit between sender and receiver. For example, seamless car entry systems verify if the car’s key is within a certain distance, otherwise the doors cannot be opened and the engine cannot be started. In contrast, mid-range radio-based communications like Bluetooth or Wi-Fi cause additional overhead to measure the round trip time between sender and receiver and estimate the distance between them. Due to the limited communication distance, visible light and ultrasound can help to enhance privacy and security of IoT communications where their data exchange can be easily regulated by obstacles such as door, walls, and windows. Radio waves penetrate spatial barriers and are hence exposed to eavesdropping and interception attacks. From a deployability perspective, ultrasound is easy to deploy and flexible owing to wide support by off-the-shelf smartphones. VLC has also seen significant advancement such as the open-source OpenVLC platform [4].

In this work, we exploit emerging communication technologies, VLC and ultrasound, to utilize the advantages of different electromagnetic spectrum for enhancing indoor IoT communication. In Section II we analyze user mobility in terms of required transmission distance and compare different wireless communication technologies regarding their suitability for indoor IoT communication. In Section III we highlight

use cases for VLC and ultrasound communication. Besides that, Section IV provides details of our VLC and ultrasound communication modules and we evaluate Wi-Fi, Bluetooth, VLC, and ultrasound in terms of maximum transmission distance, data rate, and energy consumption. In Section V we implement a secure group communication service using VLC and ultrasound to share distance-bounded information among proximate devices. Section VI highlights open questions for future research.

We summarize our contributions as follows:

- 1) We explore the feasibility of two non-radio based communications, VLC and ultrasound, and provide details about our system implementations to support indoor IoT communication.
- 2) We develop communication modules for VLC and ultrasound on off-the-shelf hardware and evaluate the prototypes with respect to communication distance, data rate, and energy consumption. Our experimental study sheds light on how to utilize those technologies in practical IoT settings.
- 3) We apply our VLC and ultrasound modules to realize a secure group communication with an automated key management. This service prototype illustrates a pragmatic use case in augmenting IoT services.

## II. INDOOR IoT COMMUNICATION

An important domain for IoT is the indoor communication where multiple wireless technologies have been developed to support large scale inter-communications. We provide a brief overview of indoor IoT communication technologies like Wi-Fi, Bluetooth (BT), VLC, and ultrasound.

To solve the network capacity problem of wireless radio-based communications, the frequency range of visible light, 430 THz to 790 THz, is 1200 times greater compared to the scope of electromagnetic waves with 3 Hz to 300 GHz. Besides that, we take advantage of ultrasound by using sound waves between 20 kHz to 24 kHz, to transmit information between devices which is inaudible for humans and can be used as out-of-band channel. Another disadvantage for radio-based technologies is the wireless interference, which can negatively affect the network performance. For example, in our testbed we observed a decrease of Wi-Fi throughput in presence of Bluetooth Low Energy (BLE) beacons by 12.12% (16.89 MB/s without BLE, and 14.84 MB/s with BLE).

For practicality, we have analyzed the mobility of users, i.e., walking distance, to show whether VLC and ultrasound are suitable for indoor IoT communications in terms of viable communication range. The dataset [5] contains the associations between 6202 users and 500 Wi-Fi access points with relative positions within university buildings. To detect a user movement, we analyze the time scale whether the associations between user and access point changes over time. Fig. 1(a) shows the users' walking distance, ranging from 6.64 m (10% of all users) to 88.57 m (85% of all users). Regarding transmitted network data, another recent study analyzed the user's data consumption and revealed that 85% of all users consume about 100 MB per day [6].

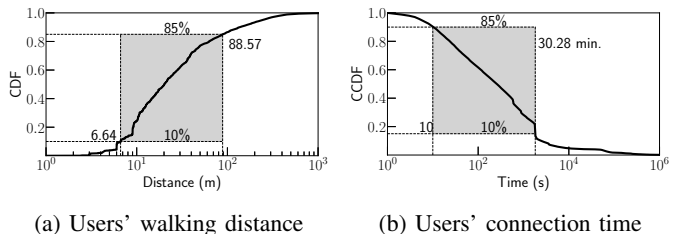

Fig. 1: Analysis of user's mobility pattern to highlight appropriate wireless communications with respect to transmission distance and connection time

By comparing maximum transmission distance and data rate, as shown in Table I, we can indicate which communication technology is suitable for indoor IoT communications. Existing ultrasound prototypes using commercial off-the-shelf smartphones provide low bit rates. This greatly limits the possible use cases and hence ultrasound is most applicable as out-of-band signaling channel but not for bulk data transmission. For instance, within a short range to exchange encryption keys for a secure group communication. Meanwhile, VLC is a viable solution as it covers a broader range of user movements and its achievable data rate is sufficient for common IoT communication tasks. The communication performance of visible light and ultrasound are mainly impacted by environmental conditions such as ambient light or ambient sound. As a distinctive attribute, the transmission range of those emerging communication technologies (i.e., visible light and ultrasound) is greatly limited by spatial barriers such as doors, walls, and windows. This makes it appropriate for distance-bounding services without additional computation overhead like with radio-based communication.

## III. USE CASES FOR VLC AND ULTRASOUND

VLC has been enabling many applications related to IoT, such as accurate indoor localization [9], human sensing, encounter detection [10], gesture recognition, and so on. Since visible light does not pass through opaque objects, it is a good candidate to realize distance-bounding wireless communication to improve its security performance. Therefore, it can be used in many potential applications, especially those that need secure proximity interaction. For example, convenient and secure entrance control (people can open a door at several meters away from it by sending the password wirelessly; the door-controller can delimit its allowed access distance, exceeding which people cannot open the door even they send a correct password), convenient and secure payment in supermarkets (no need to approach close to the reader to "touch" it for payment, which is required with NFC in order to ensure security), and robots control in smart factories (robots are allowed to access some resources through interactions only if they are physically within the delimited distance).

Ultrasound supports a range of use cases including device pairing, proximity detection, user-tailored advertisements or as mobile payment system in taxis. In case of automated device grouping and device pairing [11], [12] which is usually performed manually. The speaker emits inaudible tones which are

TABLE I: Comparison of communication technologies for indoor IoT communications [7], [8]

Communication Technology	Max. transmission distance	Max. data rate	Influence factors	Advantages
Wi-Fi	100 m	7 Gbit/s	Interference with other radio-based technologies	Unlicensed spectrum allows cost-efficient implementation
Bluetooth	100 m	24 Mbit/s	Manual pairing for device connection	Low power consumption
Visible Light	30 m	15 Gbit/s	Line of sight transmission	Privacy enhanced communication by distance restriction
Ultrasound	25 m	56 kbit/s	Low data rates and error prone decoding due to overlapping frequencies	Reliable mechanism for device grouping

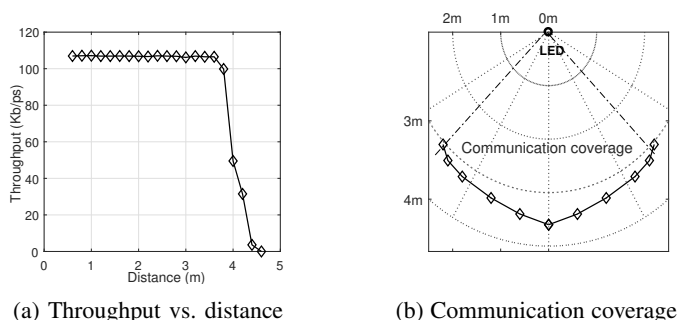

Fig. 2: Experimental results of our VLC communication module

captured only by physically proximate devices. For instance, to organize group activities, e.g., a meeting or to share documents with its members. Other systems target at proximity detection like Google Chromecast which uses ultrasound to verify whether a mobile device is in vicinity and enables sharing options. Besides that, ultrasound is widely used for proximity marketing [13]. In environments like casinos, museums, retail, airports, the user gets location-tailored advertisement based on user tracking. In shopping malls, stores track the in-store user behavior.

#### IV. COMMUNICATION MODULES AND EVALUATION

We use non-radio technologies such as VLC and ultrasound to supplement and enrich conventional radio-based communication for IoT communication. Our developed communication modules enable visible light and ultrasound supported applications. Based on live testbed experiments, we present our insights and evaluation results for these two modules in terms of throughput, transmission range, and energy consumption.

##### A. Visible Light Communication Module

Our VLC module is built around the low-cost platform BeagleBone Black (BBB) which costs around \$60. We use a Philips 4.7 W LED as the transmitter which is powered by a 24 V DC voltage. The LED is disassembled by removing the AC-DC converter that can slow down the transition speed between ON and OFF states. We adopt an advanced Adaptive Multiple Pulse Position Modulation (AMPPM) [4] scheme at the transmitter that can support dimming, instead of simple On-Off-Keying (OOK) modulation. At the receiver, incoming light signals are first sensed by a photodiode (SFH206K) and

then amplified by an amplifier (TLC237). Analog signals from the amplifier are converted to digital signals by the ADC (ADS7883) and then sampled by the BBB micro-controllers' Programmable Realtime Units (PRUs) for further computation.

The evaluation results of the achieved throughput under various distances between transmitter and receiver are shown in Fig. 2(a). The transmitter and receiver are aligned. We can observe that our low-end VLC system can work at a maximum communication distance of 3.7 m. It achieves a throughput of up to 107 kb/s which is enough for most of the IoT applications. In addition, we carry out experiments to test the VLC interface's communication converge and present the results in Fig. 2(b). We can observe that the communication range of VLC is limited, which can be well controlled by using different types of LEDs. This makes the VLC interface of our system well suitable for those applications that have high requirements on security.

Comparing our testbed results with the higher VLC performance of 15 Gb/s indicated in Table I, the performance gap is caused by the different flavors of VLC platforms using a diverse range of hardware. In addition, the testbed setting in terms of distance range and intensity of ambient light affects the perceived throughput. Our VLC platform proves that even with an off-the-shelf IoT board and low cost LED transmitters, the performance of our VLC module still satisfies the throughput requirement of IoT applications. We note that the timing function provided in the Linux kernel limits the sampling rate which becomes a major bottleneck for our VLC module. To overcome the bottleneck and achieve a higher throughput (e.g., up to several Mb/s), we can use a dedicated field programmable gate array (FPGA) or a separate micro-controller to perform signal sampling. For instance, another VLC system [14] takes advantage of laser diodes and is able to achieve better utilization of the visible light spectrum, reaching a throughput of  $\sim 15$  Gb/s.

##### B. Ultrasound Communication Module

To modulate ultrasound messages, we are using an Orthogonal Frequency-Division Multiplexed On-Off Keying (OFDM-OOK) scheme. Thereby, we use eight frequencies to address eight bits in a byte and one frequency for a parity check, encoding each bit in the byte in parallel to the same symbol. For each symbol we use a fixed duration of 46.4 ms (2048 samples at 44.1 kHz) and a guard interval of the same length between the symbols to prevent Inter-Symbol Interference

TABLE II: Evaluation results of Wi-Fi and Bluetooth compared to our communication modules including VLC and ultrasound

Communication Technology	Max. transmission distance	Max. data rate	Energy consumption
Wi-Fi	30 m	1.05 Mbit/s	sender: 3.26 $\mu$ J/Byte receiver: 8.72 $\mu$ J/Byte
Bluetooth	10 m	718.16 Kbit/s	sender: 3 $\mu$ J/Byte receiver: 4.81 $\mu$ J/Byte
Visible Light	4.5 m	500 Kbit/s	sender: 8.42 $\mu$ J/Byte receiver: 8.32 $\mu$ J/Byte
Ultrasound	50 cm	64 bit/s	sender: 25,530 $\mu$ J/Byte receiver: 31,834 $\mu$ J/Byte

(ISI). To define the start and end of the message, we use a preamble and postamble with all bits on and thrice the regular pulse length. To demodulate an ultrasound message, we need to:

- 1) convey synchronization via preamble and postamble of the message recording
- 2) perform a Short Time Fourier Transform (STFT) with a sample size matching the symbol length used for modulation
- 3) compute a signal threshold to differentiate between bit one and zero. Therefore, we inspect the amplitudes on the frequencies of interest in different samples and for each frequency separately.
- 4) extract the modulated byte sequence via computed signal threshold.

Our universal demodulation method for ultrasound messages does not require special audio hardware. In our experiments, we use commercial off-the-shelf smartphones. Today's smartphones are equipped with speakers and microphones which are capable to produce and capture sound at frequencies up to 22 kHz – 24 kHz. We tested our ultrasound modulation on a pair of Lenovo Phab 2 Pro phablets and achieved bit rates of 64 bit/s with bit error rates of less than 3% on a distance of 50 cm. To enhance demodulation robustness we use Reed-Solomon error correction. In comparison, related prototypes achieve bit rates between 8 bit/s and 1280 bit/s with a communication range from 5 cm to 25 m.

The achieved bit rate of our ultrasound modulation is appropriate for use cases where small messages are exchanged over limited communication range. For example, device pairing or key exchange protocols. The bit rate can be increased through specialized audio hardware, such as in literature [15], or through a choice of different modulation. For an overview, the authors of [16] explored several data modulation techniques in terms of their capabilities and differences.

### C. Evaluation

To highlight the usability of VLC and ultrasound in IoT environments, Table II shows the maximum transmission distance, data rate, and energy consumption for VLC and ultrasound compared to Wi-Fi and Bluetooth. For Wi-Fi energy measurements, we attached a Wi-Fi USB adapter and created an access point via hostapd to directly connect sender and

receiver. The high voltage Monsoon power device measures the energy measurements by powering our hardware platform (BeagleBone Black) with 5 V for VLC and Wi-Fi energy measurements. For ultrasound and Bluetooth, the energy measurements were taken from an Android smartphone with a detachable battery. To compute the energy measurements for Wi-Fi, Bluetooth, VLC, and ultrasound, we have taken the difference to the system's basis energy consumption, BeagleBone black and Android smartphone. During the data transmission, we measured the current (mA), power (mW) and voltage (V) and calculated the required energy in Joule per Byte. With respect to the results, Bluetooth provides the lowest energy consumption in contrast to ultrasound communication with the significantly highest energy consumption. The VLC sender requires 1.6 times more energy as the VLC receiver mainly caused by the high power LED at the sender side to transmit the encoded data via visible light. The energy consumption of VLC and ultrasound is significantly higher compared to Wi-Fi and Bluetooth, which is a drawback for IoT environments with many powered devices. VLC and ultrasound prototypes with specialized hardware can overcome this problem by increased data rates and lower energy consumption.

## V. SECURE IOT GROUP COMMUNICATION

### A. Mobile Device Grouping

To illustrate the usage of VLC and ultrasound in practice, we have developed a secure group communication using our communication modules for proximity-aware device grouping. We are able to achieve a fine-grained device discovery and provide data sharing for sensitive information based on location-restricted user access. Fig. 3(a) illustrates the setting of our secure group communication solely based on mobile devices. We identify certain mobile devices, e.g., smartphones and tablets, as supernodes based on their stronger hardware performance compared to other nearby devices. To broadcast and receive VLC messages, we connect the mobile device via Wi-Fi to our VLC platform as add-on device mentioned in Section IV-A. As out-of-band channel, the supernode broadcasts messages or tokens via VLC and/or ultrasound which are used for device grouping and to secure the radio-based communication. Due to limited VLC and ultrasound communication range, only mobile clients within a certain area are able to receive the broadcasted VLC and/or ultrasound message and hence

eligible to use the associated service, e.g., device grouping. By using these distance-limited token broadcasts, we are able to automate and ease the key management among IoT and mobile devices without user interactions like machine-to-machine communications.

We have implemented our automated device grouping on off-the-shelf Android smartphones, which can aggregate input data from Wi-Fi, ambient sound, VLC, and ultrasound. A device is eligible to participate in the group communication, if the ambient sound among the peers is similar or it's able to receive the VLC or ultrasound transmitted data. Once the device grouping service is triggered, each device advertises via Wi-Fi Direct its CPU utilization, available battery power, and memory. On this basis, the most powerful device in proximity is selected as the supernode to handle the device grouping. For Wi-Fi similarity, each device collects three Wi-Fi scans including SSID, BSSID, RSSI, and frequency. For ambient sound similarity, every device creates sound features from 10s recordings of the ambient environment including power spectrogram to quantify changes in frequency, Mel Frequency Cepstral Coefficients (MFCC) which mimics the human's perception, and a landmark fingerprint [17] generated from most robust amplitude peaks. The supernode compares these Wi-Fi and ambient sound features for automated device grouping. During experiments in different environments, we have encountered the following settings as best working. For Wi-Fi similarity using the Pearson correlation with a similarity threshold of 0.74 and for ambient sound similarity using the landmark fingerprint with a hash-based offset similarity of 0.7. In addition, our prototype utilizes VLC and ultrasound for device grouping. The supernode broadcasts an ultrasound and VLC signal with an encoded identifier. We infer that a device is in vicinity to the supernode, if the normalized string similarity based on the Levenshtein edit distance between broadcasted word and decoded identifier is greater than 0.8. At least one proximity indicator, either VLC or ultrasound, has to be true to infer that the end device is in vicinity.

We have evaluated our prototype with off-the-shelf smartphones over ten evaluation rounds in two different testbeds. In each testbed, closed and open space, we placed two test devices within the proximity to each other and one device outside of the proximity range. The closed space refers to a meeting room with size of  $4.5 \times 3.7 = 16.65 \text{ m}^2$ . The proximity is defined by the room boundaries, i.e., the device is within the room. For the second testbed, open space, we use the university entrance hall, which is crowded and noisy. In contrast to the closed environment, proximity is defined by a distance threshold of 5 m. In comparison to Wi-Fi similarity, Fig. 4(a) shows the accuracy of each device grouping based on ambient sound or VLC and ultrasound. In the closed space, i.e., meeting room, compared to the Wi-Fi based device grouping, using ambient sound achieves a 22% higher accuracy and the combination of VLC and ultrasound communication performs 27% better. In the open space, i.e., entrance hall, the proximity accuracy of ambient sound decreases by 6% and the combination of VLC and ultrasound decreases by 5%. Since the environment contains more disturbing noise

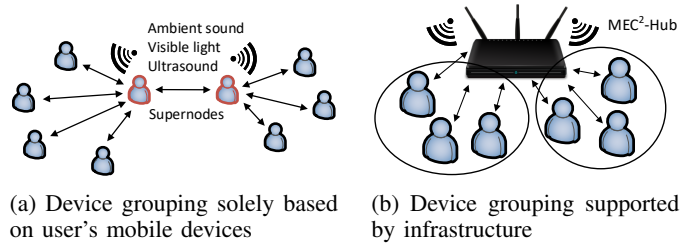

Fig. 3: Organization of IoT group communication

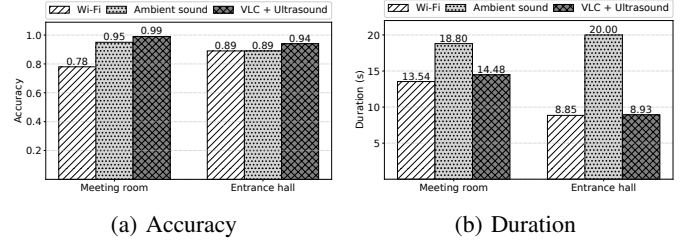

Fig. 4: Experimental results of our proximity-aware device grouping compared to using Wi-Fi

which negatively affects the sound spectrum as proximity indicator. In contrast, the proximity accuracy using Wi-Fi features increases by 11%. This indicates that Wi-Fi signals are preferably used as coarse-grained proximity indication. Besides the accuracy of proximity detection, another important factor for a satisfying user experience is the duration until the devices are grouped together as shown in Fig. 4(a). Using ambient sound features for device grouping takes significantly longer compared to Wi-Fi and the combination of VLC and ultrasound communication which achieve similar results. To sum up, the combination of VLC and ultrasound communication for device grouping outperforms Wi-Fi and ambient sound based device grouping in terms of accuracy and duration.

### B. Infrastructure-Supported Device Grouping

For our previously presented device grouping based on ambient sound, VLC, and ultrasound, an important decision is on its placement, which is affected mainly by user's mobility pattern. If the user is constantly moving the corresponding mobile device is frequently changing its access point. In this case, the device grouping as shown in Fig. 3(a) should be handled directly on the mobile devices. Fig. 1(b) shows the user's connection time to an access point which ranges from 10 min. (10% of all users) to 30 min. (85% of all users). Hence, the users are static enough that the device grouping can be offloaded to an access point as shown in Fig. 3(b).

Our communication platform named MEC<sup>2</sup>-Hub supports multi-access mobile edge computing (MA-MEC) by exploiting the integration of emerging communication technologies, visible light and ultrasound, together with radio, to utilize the advantages of different electromagnetic spectrum and realize additional services such as secure IoT group communication. MEC<sup>2</sup>-Hub is intended to run at the edge of the network, such as wireless access points or gateways to enable edge communication paths. Fig. 5 shows our proposed platform which

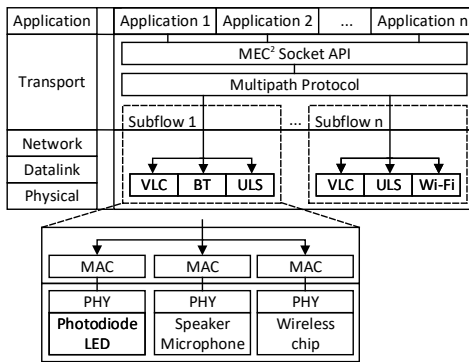

Fig. 5: MEC<sup>2</sup>-Hub as communication platform for infrastructure-supported device grouping (ULS: ultrasound)

extends the idea of multipath protocols, such as multipath TCP (MPTCP) [18] to support multiple communication paths via different communication media. Each network subflow in MEC<sup>2</sup>-Hub can use a combination of physical transmission medium, such as visible light or ultrasound with different properties regarding transmission range and data rate. The multipath protocols in MEC<sup>2</sup>-Hub allow us to dynamically switch between network interfaces at runtime without reconnecting as the mobile device’s IP address is decoupled from a specific network connection. The MEC<sup>2</sup> socket API is a major component in our platform allowing applications to interact with the MEC<sup>2</sup>-Hub networking stack. The underlying multipath protocols utilize feasible network paths via subflows for each network connection and distribute application data across those subflows. In specific, the MEC<sup>2</sup> socket API provides a socket option that third-party developers are able to explicitly specify the communication medium.

## VI. OPEN QUESTIONS AND CHALLENGES

**VLC support for mobile devices.** Existing VLC platforms require dedicated hardware boards. This greatly limits the flexibility in mobile environments. Meanwhile, most end-user devices such as smartphones are already equipped with the necessary hardware, i.e., photodiode for receiver and LED as transmitter. However, off-the-shelf devices lack support for real-time signal processing which is required for VLC. An improved support for VLC on off-the-shelf devices can greatly promote the adoption of VLC in the IoT domain.

**Energy efficiency of VLC and ultrasound communications.** To illustrate the impact, we have measured the power consumption of Bluetooth, Wi-Fi, VLC, and ultrasound. Comparing the energy consumption with Bluetooth, VLC consumes 124x more and ultrasound goes up to 7343x. For a better adoption of VLC and ultrasound in IoT domain, future research is needed to tackle the energy issue in VLC and ultrasound communications, spanning across hardware, protocol, and software implementations.

## VII. CONCLUSION

Challenging requirements for indoor IoT communication include low latency, secure connectivity, and high reliability for a large number of heterogeneous IoT applications. To fulfill

these requirements, we exploit two emerging communication technologies, visible light and ultrasound, and leverage their diverse electromagnetic spectrum to complement the conventional radio-based IoT communication. We have developed the communication modules and evaluated them in testbed environments. Our experimental study sheds light on how to apply those technologies in practice and illustrates pragmatic use cases to augment various IoT services. To demonstrate the efficacy of our approach, we further implement a practical service on off-the-shelf devices for securing IoT group communication.

## REFERENCES

- [1] Cisco, “Cisco Visual Networking Index: Global Mobile Data Traffic Forecast Update, 2016–2021,” March 28, 2017.
- [2] R. Morabito, V. Cozzolino, A. Y. Ding, N. Bejar, and J. Ott, “Consolidate IoT Edge Computing with Lightweight Virtualization,” *IEEE Network*, vol. 32, no. 1, pp. 102–111, Jan 2018.
- [3] M. Haus, A. Y. Ding, and J. Ott, “Managing IoT at the Edge: The Case for BLE Beacons,” in *Proceedings of the 3rd Workshop on Experiences with the Design and Implementation of Smart Objects (SmartObjects)*, 2017, pp. 41–46.
- [4] H. Wu, Q. Wang, J. Xiong, and M. Zuniga, “SmartVLC: When Smart Lighting Meets VLC,” in *Proceedings of the 13th International Conference on Emerging Networking Experiments and Technologies (CoNEXT)*, 2017, pp. 1–12.
- [5] D. Kotz, T. Henderson, I. Abyzov, and J. Yeo, “CRAW-DAD dataset dartmouth/campus,” Downloaded from <https://crawdad.org/dartmouth/campus/20041109/movement>, Nov. 2004.
- [6] B. Alipour, L. Tonetto, A. Y. Ding, J. Ott, R. Ketabi, and A. Helmy, “Flutes vs. Cellos: Analyzing Mobility-Traffic Correlations in Large WLAN Traces,” in *Proceedings of the IEEE International Conference on Computer Communications (INFOCOM)*, 2018, pp. 1–12.
- [7] D. Feng, L. Lu, Y. Yuan-Wu, G. Y. Li, S. Li, and G. Feng, “Device-to-Device Communications in Cellular Networks,” *IEEE Communications Magazine*, vol. 52, no. 4, pp. 49–55, 2014.
- [8] A. Gupta and R. K. Jha, “A Survey of 5G Network: Architecture and Emerging Technologies,” *IEEE Access*, vol. 3, pp. 1206–1232, 2015.
- [9] T. Li, Q. Liu, and X. Zhou, “Practical Human Sensing in the Light,” in *Proceedings of the 14th International Conference on Mobile Systems, Applications and Services (MobiSys)*, 2016, pp. 71–84.
- [10] H. Zhang, W. Du, P. Zhou, M. Li, and P. Mohapatra, “DopEnc: Acoustic-based Encounter Profiling Using Smartphones,” in *Proceedings of the 22nd Annual International Conference on Mobile Computing and Networking (MobiCom)*, 2016, pp. 294–307.
- [11] A. Matic, O. Mayora-Ibarra, A. Maxhuni, and V. Osmani, “Virtual Uniforms: Using Sound Frequencies for Grouping Individuals,” in *Proceedings of the ACM Conference on Pervasive and Ubiquitous Computing Adjunct Publication (UbiComp Adjunct)*, 2013, pp. 159–162.
- [12] D. Gijsbrecht, F. Heller, J. Schöning, and F. Kawsar, “Grouve: Spontaneous Proximal Group Formation with Ultrasonic Sound Waves,” in *Proceedings of the 8th EAI International Conference on Mobile Computing, Applications and Services (MobiCASE)*, 2016, pp. 140–141.
- [13] V. Mavroudis, S. Hao, Y. Fratantonio, F. Maggi, C. Kruegel, and G. Vigna, “On the Privacy and Security of the Ultrasound Ecosystem,” in *Proceedings of the 17th Privacy Enhancing Technologies Symposium (PETS)*, 2017, pp. 1–18.
- [14] D. Tsonev, S. Videv, and H. Haas, “Towards a 100 Gb/s Visible Light Wireless Access Network,” *Optics Express*, vol. 23, no. 2, pp. 1627–1637, 2015.
- [15] W. Jiang and W. M. Wright, “Ultrasonic Wireless Communication in Air using OFDM-OOK Modulation,” in *Proceedings of the International Ultrasonics Symposium (IUS)*, 2014, pp. 1025–1028.
- [16] V. Gerasimov and W. Bender, “Things that Talk: Using Sound for Device-to-Device and Device-to-Human Communication,” *IBM Systems Journal*, vol. 39, no. 3.4, pp. 530–546, 2000.
- [17] Avery Li-chun Wang, “An Industrial-Strength Audio Search Algorithm,” in *Proceedings of the 4th International Conference on Music Information Retrieval (ISMIR)*, 2003, pp. 1–7.
- [18] C. Paasch and O. Bonaventure, “Multipath TCP,” *Communications of the ACM*, vol. 57, no. 4, pp. 51–57, 2014.